

# S & R

Flanged Safety Relief Valves  
for special or  
regional applications

Series SBD

Series TRDF

Series TRDG



# CATALOG

**LESER**

[The-Safety-Valve.com](http://The-Safety-Valve.com)

## Product group

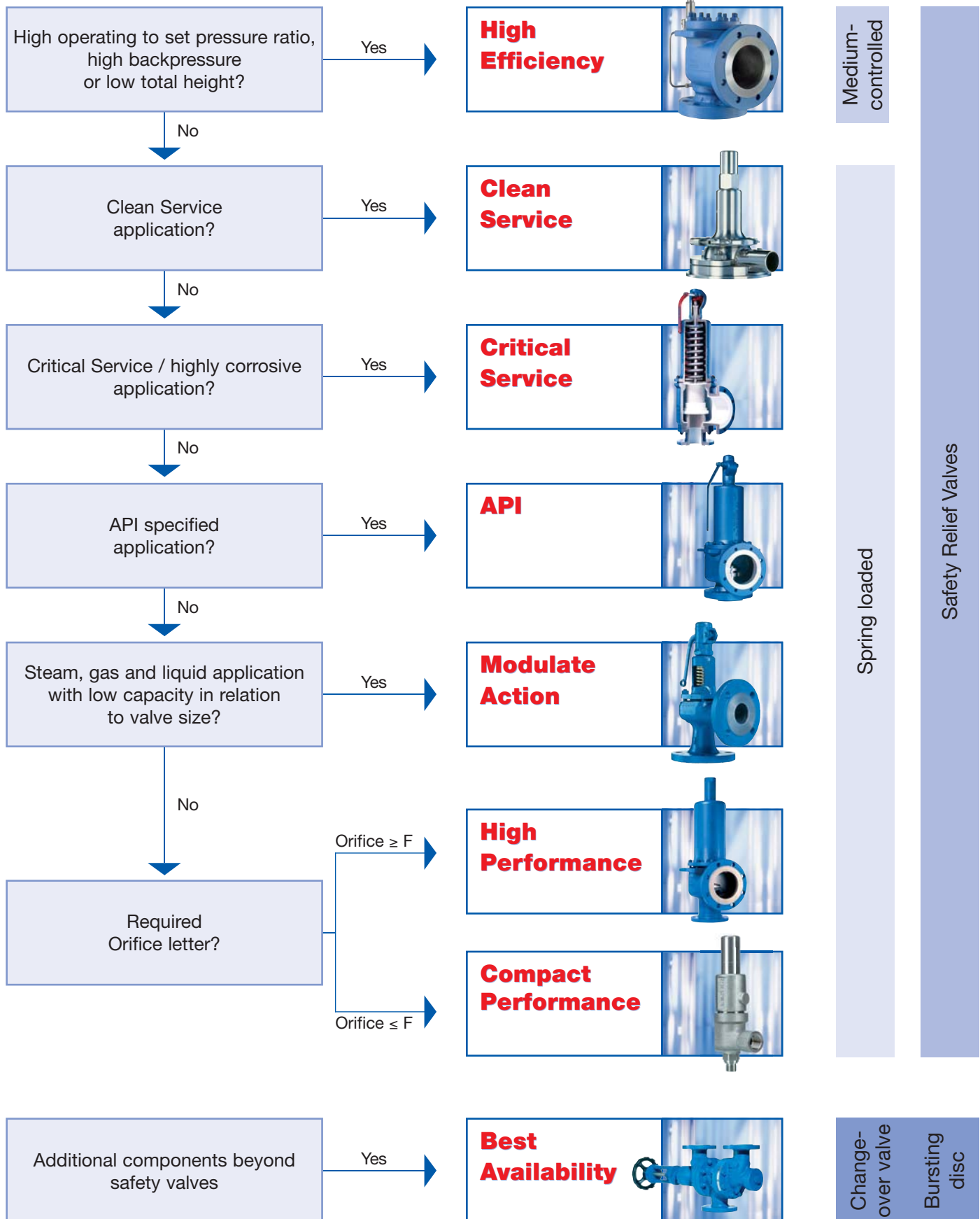

**Type  
532, 534**

# Durchgangs-Proportional-Feder-Sicherheitsventil bis PN 40 In-Line Relief Valve up to PN 40 spring loaded

für Dämpfe, Gase und Flüssigkeiten  
for steam, gases and liquids

## Zusatz-ausrüstungen

Edelstahl-Faltenbalg  
Elastomer-Faltenbalg  
Teller mit Weichdichtung ab DN 20  
Teller/Sitz gepanzert

**Detailinformationen und weitere  
Zusatz-ausrüstungen siehe Teil 13**

## Accessories

Stainless steel bellows  
Elastomer bellows  
Disc with soft seal from DN 20  
Disc / Seat stellited

**For detailed information and additional  
accessories refer to section 13**

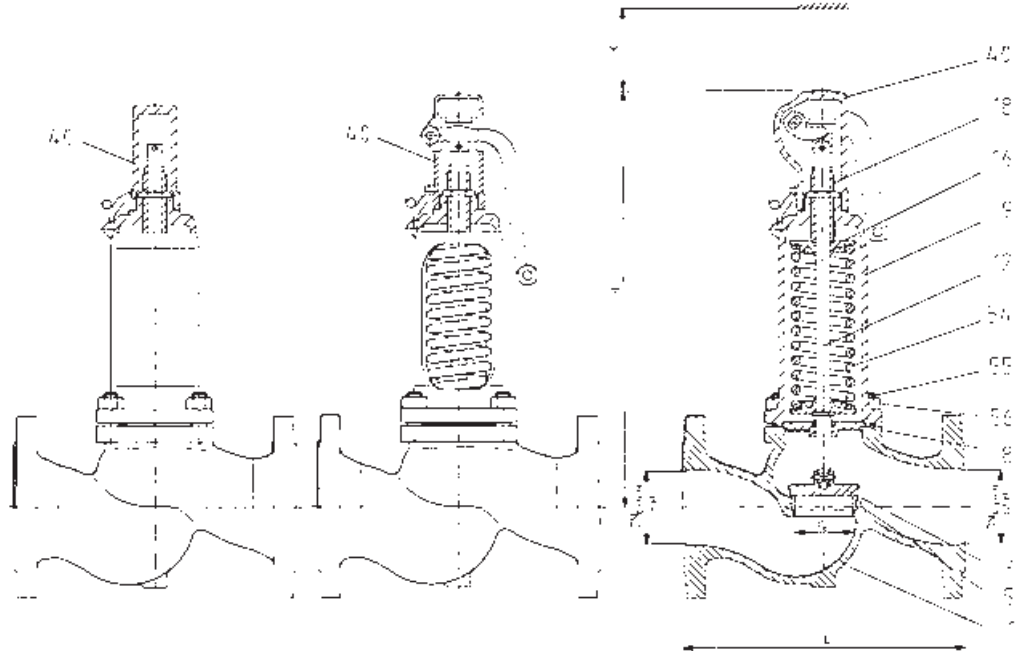

**Type 534**  
mit gasdichter Kappe H 2  
with gastight cap H 2

**Type 532**  
offene Federhaube mit Anlüftung H 3  
Teller anlüftbar  
open bonnet lifting device H 3  
disc liftable

**Type 534**  
geschlossene Federhaube mit Anlüftung H 4  
Teller anlüftbar  
closed bonnet lifting device H 4  
disc liftable

## Zulassungen / Approvals

EG-Bauteilprüf-nr./EC-type examination no. 07 202 0111 Z00080/15	Dämpfe/Gase D/G Steam/Gases S/G				Flüssigkeiten F Liquids L			
	<b>TÜV (AD-A2, TRD 421)</b> Listennr./Approval number Ausflußziffer/Coefficient of discharge $\alpha_d$ Öffnungscharakteristik/Opening characteristic	DN 20 – 50 432 0,08		DN 65 – 150 432 0,12		DN 20 – 50 nur mit O-Ring-Teller/with O-ring disc only 432 0,09		
	Proportional/Proportional				Proportional/Proportional			
<b>Weitere/Others</b> siehe Seite/refer to page 2/40-41	DGR/PED	DNV	GL	KISCO	RINA	TMB		

Gehäusewerkstoff Body material		DN		Flanschanschlüsse <sup>1)</sup> Flange connections <sup>1)</sup> nach/acc. to DIN PN		Temperatureinsatzbereich °C <sup>2)</sup> Temperature range °F <sup>2)</sup>		Type Federhaube Bonnet	
Werkstoffbezeichnung Material Designation	Werkstoff-Nr. Material No.	von from	bis to	Eintritt Inlet	Austritt Outlet	von from	bis to	geschl. closed	open
GG-25	0.6025	15	150	16	16	-10/+14	+300/+572	<b>5341</b>	<b>5321</b>
GP 240 GH	1.0619	15	125	40	40	-85/-121	+400/+752	<b>5342</b>	<b>5322</b>

<sup>1)</sup> Anschlußmaße nach ANSI B16.5 150 lbs. möglich.  
<sup>2)</sup> Zwischen -10 °C und der niedrigsten, angegebenen Anwendungstemperatur ist gemäß AD-Merkblatt W10 zu verfahren.

<sup>1)</sup> Dimensions acc. to ANSI B16.5 150 lbs. possible.  
<sup>2)</sup> Between -10 °C and lowest temperature indicated "AD-Merkblatt" W10 shall be taken into account.

Änderungen behalten wir uns vor.

Modifications reserved.

## Artikelnummern / Article Numbers

Gehäusewerkstoff <i>Body material</i>			Nennweite / Nominal Diameter											
			15	20	25	32	40	50	65	80	100	125	150	
Federhaube / Bonnet	geschlossen closed	GG-25 0.6025	<b>5341</b>	.174*	.175*	.176*	.177*	.178*	.179*	.180*	.181*	.182*	.183*	.184*
		GP 240 GH 1.0619	<b>5342</b>	.186*	.187*	.188*	.189*	.190*	.191*	.192*	.193*	.194*	.195*	-
	offen open	GG-25 0.6025	<b>5321</b>	.1745	.1755	.1765	.1775	.1785	.1795	.1805	.1815	.1825	.1835	.1845
		GP 240 GH 1.0619	<b>5322</b>	.1865	.1875	.1885	.1895	.1905	.1915	.1925	.1935	.1945	.1955	-

\* Bitte hier gewünschte Ziffer für Kappe oder Anlüftung anfügen:

- 2 = Kappe **H 2**
- 3 = Anlüftung **H 3** (offen)
- 4 = Anlüftung **H 4** (gasdicht)

\* Please add number for the required cap or lifting device:

- 2 = Cap **H 2**
- 3 = Lifting device **H 3** (open)
- 4 = Lifting device **H 4** (gastight)

Bei Bestellung bitte Artikelnummer entsprechend Bestellbeispiel im Teil 1, Ansprechdruck und ggf. Zusatzausrüstung (siehe Teil 13) angeben.

In event of order please state article number corresponding to the example for ordering in section 1, set pressure and if necessary, accessories (refer to section 13).

## Abmessungen, Druckbereiche, Gewichte / Dimensions, Pressure Ranges, Weights

Nennweite, Ventilgröße		Nominal Diameter, Valve size		DN	-	15	20	25	32	40	50	65	80	100	125	150
Nennweite, Austritt		Nominal Diameter, Outlet		DN	-	15	20	25	32	40	50	65	80	100	125	150
Druckstufe	GG	Pressure rating	CI	PN	-	16										
Eintritt	GS	Inlet	CS	PN	-	40										
Druckstufe Austritt		Pressure rating Outlet		PN	-	GG / CI: 16, GS / CS: 40										
Max.	GG	Max.	CI	p	bar/bar g	16	16	16	16	16	16	16	16	16	16	16
Ansprechdruck	GS	Set pressure	CS	p	bar/bar g	40	40	40	40	40	40	40	30	30	20	16
Engster Strömungsquerschnitt		Flow area		A <sub>O</sub>	mm <sup>2</sup>	177	316	491	804	1256	1963	1963	3217	4778	7543	12272
Engster Strömungsdurchmesser		Flow diameter		d <sub>O</sub>	mm	15	20	25	32	40	50	50	64	78	98	125
Baulänge		Face to face dim.		L	mm	130	150	160	180	200	230	290	310	350	400	480
Bauhöhe	H 2 GG	Height	H 2 CI	H	mm	235	240	240	260	340	380	380	440	530	610	665
	H 3		H 3	H	mm	235	240	240	260	350	390	390	450	575	650	710
	H 4 GS	with bellows add.	H 4 CS	H	mm	235	240	240	260	360	400	400	460	575	650	710
	mit Faltenbalg zus.		H	mm	35	30	30	35	55	65	60	70	75	80	95	
Deckenfreiheit		Height clearance		x	mm	150	150	150	200	200	250	250	300	350	400	450
Gewicht		Weight		-	kg	5	6	7	9	12	16	19	26	41	54	80

## Werkstoffe / Materials

Pos. Item	Bauteile	Parts	5321/5341		5322/5342	
			GG CI	0.6025	GS CS	1.0619
1	Gehäuse	Body	GG-25	0.6025	GP 240 GH	1.0619
5	Sitz	Seat	X 2 Cr Ni Mo Ti 17-12-2			1.4404
7	Teller	Disc	X 39 Cr Mo 17-1			1.4122
8	Führungsscheibe mit Buchse	Guide with bush	X 14 Cr Mo S 17/C35/GGG-40			1.4104/1.0501/0.7040
			X 14 Cr Mo S 17 tenifer			1.4104 tenifer
9	Federhaube	Bonnet	GGG-40 (GGG-40.3/GP 240 GH)			0.7040 (0.7043/1.0619)
12	Spindel	Spindle	X 20 Cr 13			1.4021
16	Federteller	Spring plate	11 S Mn Pb 30			1.0718
18	Druckschraube mit Buchse	Adjusting screw with bush	X 14 Cr Mo S 17			1.4104
			PTFE			PTFE
54	Feder	Spring	Federstahldraht C/Spring steel wire C			
			54 Si Cr 6/51 Cr V 4/X 10 Cr Ni 18-8			1.1200/1.7102/1.8159/1.4310
			54 Cr Si 6/51 Cr V 4/X 10 Cr Ni 18-8			1.7102/1.8159/1.4310
40	Kappe H 2	Cap H 2	11 S Mn Pb 30/GGG 40.3			1.0718/0.7043
	Anlüftung H 3	Lifting device H 3	GGG-40			0.7040
	Anlüftung H 4	Lifting device H 3	GGG-40			0.7040
55/ 56	Stiftschraube und Mutter	Bolt and nut	Ck 35/C 35			1.1181/1.0501
			A 4-70/A 4			1.4401/1.4401

# Type 532, 534

Leistungstabelle				Discharge Capacities			
Berechnungen aus VALVESTAR® 6.2.50				Calculations from VALVESTAR® 6.2.50			
Berechnung entsprechend DIN 3320, AD2000-Merkblatt A2, TRD 421				Calculations of mass flow according to DIN 3320, AD2000-Merkblatt A2, TRD 421			
p	Ansprechüberdruck			Set pressure			bar g
I	Sattdampf			Saturated steam			kg/h
II	Luft bei 0°C und 1013 mbar			Air at 0°C and 1013 mbar			m <sup>3</sup> /h
III	Wasser bei 20°C			Water at 20°C			10 <sup>3</sup> kg/h

DN	15			20			25			32			40			50		
d <sub>o</sub> (mm)	15			20			25			32			40			50		
p	I	II	III	I	II	III	I	II	III <sup>2)</sup>	I	II	III <sup>2)</sup>	I	II	III <sup>2)</sup>	I	II	III <sup>2)</sup>
4	15	20		75	92	3,02	117	144	4,71	192	237	7,72	301	370	12,1	470	578	18,9
5	18	24		90	111	3,37	141	174	5,27	230	285	8,63	360	445	13,5	562	695	21,1
6	21	28		105	130	3,69	164	203	5,77	268	333	9,46	419	520	14,8	655	813	23,1
7	24	32		119	149	3,99	186	233	6,24	305	381	10,2	477	596	16,0	745	931	24,9
8	27	36		134	168	4,27	209	262	6,67	343	429	10,9	536	671	17,1	837	1048	26,7
9	30	40		149	187	4,52	232	291	7,07	380	478	11,6	594	746	18,1	929	1166	28,3
10	33	44		163	205	4,77	255	321	7,45	418	526	12,2	653	822	19,1	1020	1284	29,8
12	39	52		193	243	5,22	301	380	8,16	493	622	13,4	770	972	20,9	1203	1519	32,7
14	45	60		221	281	5,64	346	439	8,82	566	719	14,4	885	1123	22,6	1383	1754	35,3
16	51	68		250	318	6,03	391	497	9,43	641	815	15,4	1002	1273	24,1	1565	1990	37,7
18	56	76		280	356	6,40	437	556	10,0	716	911	16,4	1119	1424	25,6	1748	2225	40,0
20	62	84		309	394	6,75	483	615	10,5	791	1008	17,3	1236	1575	27,0	1932	2460	42,2
22	68	92		338	431	7,07	527	674	11,1	864	1104	18,1	1350	1725	28,3	2109	2696	44,2
24	74	100		367	469	7,39	573	733	11,5	939	1200	18,9	1468	1876	29,6	2293	2931	46,2
26	80	108		396	507	7,69	619	792	12,0	1015	1297	19,7	1585	2026	30,8	2477	3166	48,1
28	86	116		426	544	7,98	665	850	12,5	1090	1393	20,4	1703	2177	31,9	2662	3402	49,9
30	92	124		455	582	8,26	712	909	12,9	1166	1490	21,1	1822	2328	33,0	2847	3637	51,6
32	98	132		485	620	8,53	758	968	13,3	1242	1586	21,8	1941	2478	34,1	3033	3872	53,3
34		140			657	8,79		1027	13,7		1682	22,5		2629	35,2		4108	55,0
6		149			695	9,05		1086	14,1		1779	23,2		2779	36,2		4343	56,6
38		157			733	9,30		1145	14,5		1875	23,8		2930	37,2		4578	58,1
40		165			770	9,54		1203	14,9		1972	24,4		3081	38,2		4813	59,6

2) Bauteilprüfung für Flüssigkeiten nur mit O-Ring-Teller! Type test approved for liquids only with o-ring-disc

DN	65			80			100			125			150		
d <sub>o</sub> (mm)	50			64			78			98			98		
p	I	II		I	II		I	II		I	II		I	II	
3	565	690		925	1130		1374	1679		2169	2650		3529	4312	
4	705	866		1154	1420		1714	2109		2706	3328		4403	5415	
5	844	1043		1382	1709		2053	2538		3241	4006		5273	6518	
6	982	1219		1609	1998		2391	2968		3774	4685		6140	7621	
7	1118	1396		1831	2287		2720	3397		4294	5363		6985	8724	
8	1255	1572		2057	2576		3055	3827		4823	6041		7846	9828	
9	1393	1749		2282	2865		3390	4256		5351	6719		8706	10931	
10	1530	1925		2507	3155		3724	4686		5879	7397		9565	12034	
12	1805	2278		2958	3733		4393	5545		6935	8753		11282	14240	
14	2074	2631		3398	4311		5048	6404		7968	10109		12963	16446	
16	2348	2984		3847	4890		5715	7263		9021	11465		14676	18652	
18	2623	3337		4297	5468		6382	8122		10075	12821			20858	
20	2898	3690		4747	6046		7051	8981		11131	14177			23065	
22	3164	4043		5184	6625		7700	9840		12156	15533			25271	
24	3440	4396		5635	7203		8370	10699			16889			27477	
26	3716	4749		6088	7781		9042	11558			18245			29683	
28	3992	5102		6541	8360		9716	12417			19601			31889	
30	4270	5455		6996	8938		10392	13276			20957			34096	
32	4549	5808		7453	9516			14135			22313			36302	
34		6161			10095			14994			23669			38508	
36		6514			10673			15853			25025			40714	
38		6867			11251			16712			26381			42920	
40		7220			11830			17571			27737			45126	

**Type  
440**

## Sicherheitsventil nach TRD 721 Abschnitt 6

### Safety Valve acc. to TRD 721 section 6

für Wasserheizungsanlagen bis 120 °C nach DIN 4751 Teil 2  
for Heating Plants up to 120 °C acc. to DIN 4751 part 2

#### Zusatzausrüstungen

Hubbegrenzung  
Gehäuse aus GP 240 GH  
bzw. GGG-40.3  
Entwässerungsbohrung

#### Accessories

Lift stopper  
Body in cast steel resp. nodular cast iron  
Drain hole

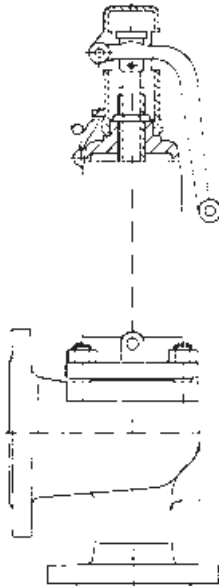

Elastomer-Faltenbalg  
zum Schutz der gleitenden und beweglichen  
Teile sowie der Feder,  
Teller mit metallisch abgestützter  
O-Ring-Abdichtung  
Elastomer bellows for protection of sliding  
and moving parts as well as the spring,  
metallic supported O-ring disc

**Type 440**  
mit Anlüftung und Kontrollbohrung  
with lifting device and inspection hole

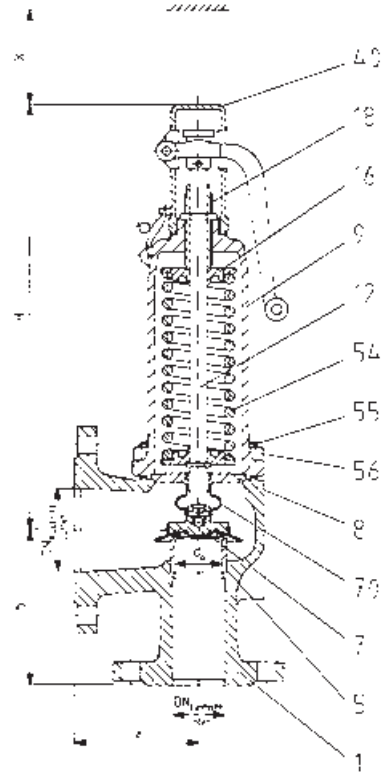

#### Zulassungen/Approvals

	Dämpfe/Gase/Heizung D/G/H Steam/Gases/Heating S/G/H
<b>TÜV (TRD 721)</b>	
Listennr./Approval number	637
Ausflußziffer/Coefficient of discharge $\alpha_d$	0,7
Öffnungscharakteristik/Opening characteristic	Normal/Standard

Gehäusewerkstoff Body material		Flanschanschlüsse Flange connections nach/acc. to DIN PN		Artikelnummer Article number										
DIN EN		Eintritt Inlet	Austritt Outlet	4401	DN									
Werkstoffbezeichnung Material Designation	Werkstoff-Nr. Material No.				20	25	32	40	50	65	80	100	125	150
GG-25	0.6025	16	16	4401	.3501	.3511	.3521	.3531	.3541	.3551	.3561	.3571	.3581	.3591

Bei Bestellung bitte Artikelnummer entsprechend Bestellbeispiel im Teil 1, An-  
sprechdruck und ggf. Zusatzausrüstung angeben.

Please state article number corresponding to the example for ordering in section  
1, set pressure and if necessary, accessories.

Änderungen behalten wir uns vor.

Modifications reserved.

## Abmessungen, Druckbereiche, Gewichte / Dimensions, Pressure Ranges, Weights

Nennweite, Ventilgröße	Nominal Diameter, Valve size	DN	-	20	25	32	40	50	65	80	100	125	150	
Nennweite, Austritt	Nominal Diameter, Outlet	DN	-	32	40	50	65	80	100	125	150	200	250	
Druckstufe Eintritt	Pressure rating Inlet	PN	-	16										
Druckstufe Austritt	Pressure rating Outlet	PN	-	16										
Max. Ansprechdruck	Max. Set pressure	p	bar/bar g	10										
Engster Strömungsquerschnitt	Flow area	A <sub>0</sub>	mm <sup>2</sup>	254	416	661	1075	1662	2829	4301	6648	7543	12272	
Engster Strömungsdurchmesser	Flow diameter	d <sub>0</sub>	mm	18	23	29	37	46	60	74	92	98	125	
Schenkellänge	Centre to face dim.	a	mm	95	100	110	115	120	140	160	180	200	225	
		b	mm	85	105	115	140	150	170	195	220	250	285	
Bauhöhe	Height	H	mm	215	225	325	370	415	530	605	660	660	735	
Deckenfreiheit	Height clearance	x	mm	150	150	200	250	300	350	400	450	450	450	
Gewicht	Weight	-	kg	9	9	12	16	22	32	56	75	85	131	

Leistungstabelle		Discharge Capacities	
Berechnung entsprechend TRD 721		Calculation of mass flow according to TRD 721	
p	Ansprechüberdruck	Set pressure	
l	Sattdampf	Sat. steam	
ll	Wärmeleistung	Heating capacity	
		bar/bar g	
		kg/h	
		kW	

DN	20		25		32		40		50		65		80		100		125		150	
d <sub>0</sub> (mm)	18		23		29		37		46		60		74		92		98		125	
p	l	ll	l	ll	l	ll	l	ll	l	ll	l	ll	l	ll	l	ll	l	ll	l	ll
1.0	189	115	308	188	490	298	798	486	1230	751	2090	1280	3190	1940	4930	3000	5590	3410	9100	5540
1.5	247	149	403	243	641	387	1040	631	1610	975	2740	1660	4170	2520	6440	3900	7310	4420	11900	7200
2.0	302	180	493	294	783	468	1270	762	1970	1180	3350	2000	5100	3050	7880	4710	8940	5340	14500	8690
2.5	355	212	579	345	921	549	1490	894	2310	1380	3940	2350	5990	3580	9260	5530	10500	6270	17100	10200
3.0	406	240	663	392	1050	623	1710	1010	2650	1570	4510	2670	6860	4050	10600	6270	12000	7110	19500	11600
3.5	456	268	745	437	1180	695	1920	1130	2980	1750	5070	2980	7710	4530	11900	7000	13500	7940	22000	12900
4.0	507	295	827	482	1310	767	2140	1250	3300	1930	5620	3280	8560	4990	13200	7720	15000	8760	24400	14200
4.5	557	323	909	527	1440	838	2350	1360	3630	2110	6180	3590	9400	5460	14500	8430	16500	9570	26800	15600
5.0	607	350	990	571	1570	908	2560	1480	3960	2280	6740	3890	10200	5910	15800	9140	17900	10400	29200	16900
5.5	656	377	1070	615	1700	978	2770	1590	4280	2460	7290	4190	11000	6370	17100	9840	19400	11200	31600	18200
6.0	706	403	1150	658	1830	1050	2980	1700	4610	2630	7840	4480	11900	6810	18400	10600	20900	12000	34000	19400
7.0	806	456	1310	744	2090	1180	3400	1930	5260	2980	8950	5060	13600	7700	21000	11900	23800	13500	38800	22000
8.0	905	507	1470	828	2340	1320	3820	2140	5910	3310	10000	5640	15200	8580	23600	13300	26800	15000	43600	24500
9.0	1000	558	1630	911	2600	1450	4240	2360	6550	3650	11100	6200	16900	9430	26200	14600	29700	16500	48400	26900
10.0	1100	608	1800	993	2860	1580	4660	2570	7200	3970	12200	6760	18600	10300	28800	15900	32600	18000	53100	29300

## Werkstoffe / Materials

Pos. Item	Bauteile	Parts	4401 GG CI
1	Gehäuse	Body	GG-25 (GGG-40.3/GP 240 GH) 0.6025 (0.7043/1.0619)
5	Sitz	Seat	X2 Cr Ni Mo 17-12-2 1.4404
7	O-Ring-Teller	O-Ring-Disc	X 39 Cr Mo 17-1/EPDM 1.4122/EPDM
8	Führungsscheibe mit Buchse	Guide with bush	X 14 Cr Mo S 17/C35/GGG-40 1.4104/1.0501/0.7040 X 14 Cr Mo S 17 tenifer 1.4104 tenifer
9	Federhaube	Bonnet	GGG-40 0.7040
12	Spindel	Spindle	X 20 Cr 13 1.4021
16	Federteller	Spring plate	11 S Mn Pb 30 1.0718
18	Druckschraube mit Buchse	Adjusting screw with bush	X 14 Cr Mo S 17/X 2 Cr Ni Mo 17-12-2 1.4104/1.4404 PTFE PTFE
54	Feder	Spring	Federstahldraht C/Spring steel wire C 54 Si Cr 6/51 Cr V 4/X 10 Cr Ni 18-8 1.1200/1.7102/1.8159/1.4310
40	Anlüftung H 3	Lifting device H 3	GGG-40 0.7040
55/	Stiftschraube	Bolt	
56	Mutter	nut	Ck 35/C 35 1.1181/1.0501
70	Faltenbalg	Bellows	EPDM EPDM

### Größenbemessung für Ausdehnungswasser

Zur Absicherung von indirekt beheizten Wärmeerzeugern nach DIN 4751 Teil 2, Abschnitt 8.1, letzter Absatz (Ausdehnungswasser), ist für Wärmeleistungen bis zu 5.000 kW bei 1 bar und bis zu 18.000 kW bei 10 bar stets die DN 20 der Type 440 einzusetzen. – Die für größere Leistungen erforderlichen Nennweiten entnehmen Sie bitte der Leistungstabelle der Type 441 auf Seite 4/13. Die dort angegebene Leistung in kg/h Wasser entspricht der Wärmeleistung in kW.

### Sizing for Water Expansion

In order to protect indirectly heated hot water generators acc. to DIN 4751, part 2, section 8.1, last paragraph (water expansion) it is necessary in all cases to fit always type 440 DN 20 for heat capacities up to 5000 kW at 1 bar g and up to 18000 kW at 10 bar g. – For the required nominal sizes for bigger capacities refer to the water capacity table of type 441 on page 4/13. The capacities in kg/h stated are equivalent to the heat capacities in kW.

**Type  
424**

## Sicherheitsventil nach TRD 721 Abschnitt 5

### Safety Valve acc. to TRD 721 section 5

für Dampferzeuger bis 1 bar Überdruck  
for Steam Boilers up to 1 bar g

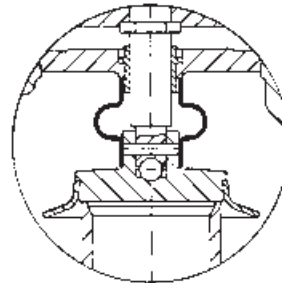
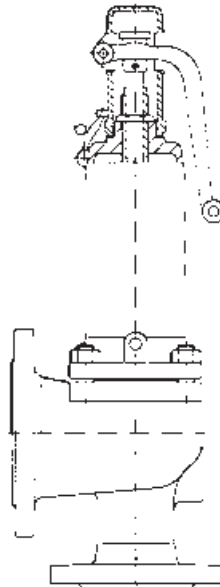

**Elastomer-Faltenbalg**  
zum Schutz der gleitenden und beweglichen Teile sowie der Feder  
**Elastomer bellows**  
for protection of sliding and moving parts as well as the spring

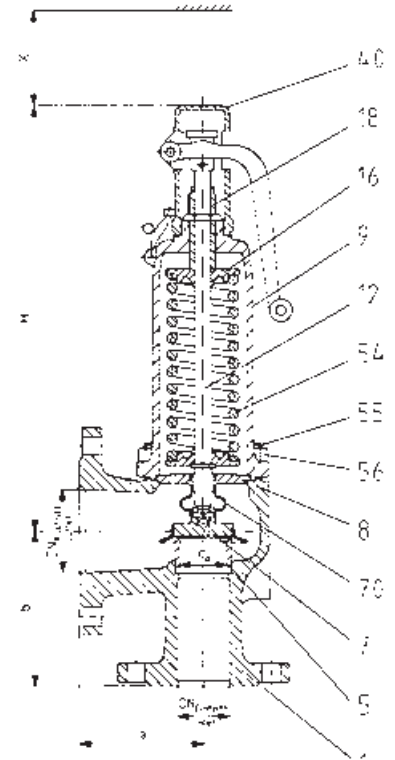

#### Zusatz-ausrüstungen

Gehäuse aus GP 240 GH  
Entwässerungsbohrung

#### Accessories

Body in cast steel  
Drain hole

**Type 424**  
mit Anlüftung und Kontrollbohrung  
with lifting device and inspection hole

**Bauteilgeprüft:** TÜV-SV...-676 • d<sub>0</sub> • D • Q • p als Vollhub-Sicherheitsventil  
Gültigkeitsbereich: Seite 2/30-33  
as full lift safety valve  
**Type test approved:** Application range: page 2/30-33  
Q = zuerkannter Massenstrom  
certified capacity (kg/h)

Gehäusewerkstoff Body material		Flanschanschlüsse Flange connections nach/acc. to DIN PN		Ansprechdruck Set pressure bar/bar g	Artikelnummer Article number									
DIN EN Werkstoffbezeichnung Material Designation	DIN EN Werkstoff-Nr. Material No.	Eintritt Inlet	Austritt Outlet		DN									
					25	32	40	50	65	80	100	125	150	
GG-25	0.6025	16	16	0,5	<b>4241</b>	.3011	.3021	.3031	.3041	.3051	.3061	.3071	.3081	.3091
GG-25	0.6025	16	16	1,0	<b>4241</b>	.3411	.3421	.3431	.3441	.3451	.3461	.3471	.3481	.3491

Bei Bestellung bitte Artikelnummer entsprechend Bestellbeispiel im Teil 1 und Ansprechdruck angeben.

Please state article number corresponding to the example for ordering in section 1, set pressure and if necessary, accessories.

Änderungen behalten wir uns vor.

Modifications reserved.



## Abmessungen, Druckbereiche, Gewichte / Dimensions, Pressure Ranges, Weights

Nennweite, Ventilgröße	Nominal Diameter, Valve size	DN	-	25	32	40	50	65	80	100	125	150	
Nennweite, Austritt	Nominal Diameter, Outlet	DN	-	40	50	65	80	100	125	150	200	250	
Druckstufe Eintritt	Pressure rating Inlet	PN	-	16									
Druckstufe Austritt	Pressure rating Outlet	PN	-	16									
Max. Ansprechdruck	Max. Set pressure	p	bar/bar g	1									
Engster Strömungsquerschnitt	Flow area	A <sub>0</sub>	mm <sup>2</sup>	416	661	1075	1662	2829	4301	6648	7543	12272	
Engster Strömungsdurchmesser	Flow diameter	d <sub>0</sub>	mm	23	29	37	46	60	74	92	98	125	
Schenkellänge	Centre to face dim.	a	mm	100	110	115	120	140	160	180	200	225	
		b	mm	105	115	140	150	170	195	220	250	285	
Bauhöhe	Height	H	mm	225	325	370	415	530	605	660	660	735	
Deckenfreiheit	Height clearance	x	mm	150	200	250	300	350	400	450	450	450	
Gewicht	Weight	-	kg	9	12	16	22	32	56	75	85	131	

## Werkstoffe / Materials

Pos. Item	Bauteile	Parts	4241 GG Cl	
1	Gehäuse	Body	GG-25	0.6025
5	Sitz	Seat	X 2 Cr Ni Mo 17-12-2	1.4404
7	Teller	Disc	X 39 Cr Mo 17-1	1.4122
8	Führungsscheibe mit Buchse	Guide with bush	X 14 Cr Mo S 17/C35/GGG-40 X 14 Cr Mo S 17 tenifer	1.4104/1.0501/0.7040 1.4104 tenifer
9	Federhaube	Bonnet	GGG-40	0.7040
12	Spindel	Spindle	X 20 Cr 13	1.4021
16	Federteller	Spring plate	11 S Mn Pb 30	1.0718
18	Druckschraube mit Buchse	Adjusting screw with bush	X 14 Cr Mo S 17 PTFE	1.4104 PTFE
54	Feder	Spring	Federstahlraht / Spring steel wire	
40	Anlüftung H 3	Lifting device H 3	GGG-40	0.7040
55/ 56	Stiftschraube Mutter	Bolt nut	Ck 35/C. 35	1.1181/1.0501
70	Faltenbalg	Bellows	EPDM	EPDM

Leistungstabelle			Discharge Capacities		
Massenstrom entsprechend TRD 721 bezogen auf 0,1 bar Drucksteigerung			Mass flow according to TRD 721 related to 0,1 bar overpressure		
p	Ansprechüberdruck		Set pressure		bar/bar g
l	Sattdampf		Sat. steam		kg/h

DN	25	32	40	50	65	80	100	125	150
α <sub>0</sub> (mm)	23	29	37	46	60	74	92	98	125
p	l	l	l	l	l	l	l	l	l
0,5	189	400	650	950	1600	2450	3800	4350	6900
1	290	460	750	1160	1975	3000	4650	5270	8580

**Type  
460**

# Sicherheitsventil nach TRD 721 Abschnitt 6 Safety Valve acc. to TRD 721 section 6

für Wasserheizungsanlagen bis 120 °C nach DIN 4751 Teil 2  
for Heating Plants up to 120 °C acc. to DIN 4751 part 2

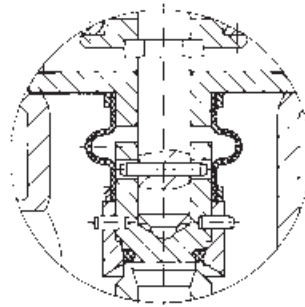
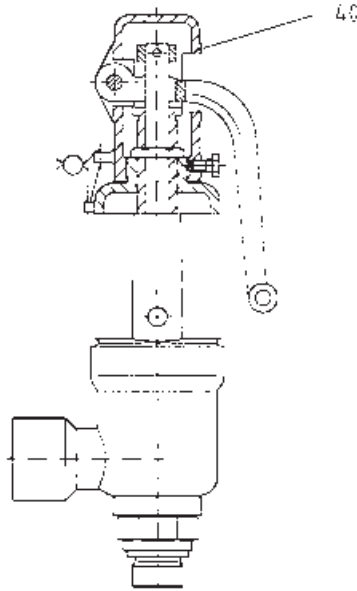

**Elastomer-Faltenbalg**  
zum Schutz der gleitenden und beweglichen Teile sowie der Feder,  
Teller mit metallisch abgestützter  
O-Ring-Abdichtung  
**Elastomer bellows**  
for protection of sliding and moving parts  
as well as the spring,  
metallic supported O-ring disc

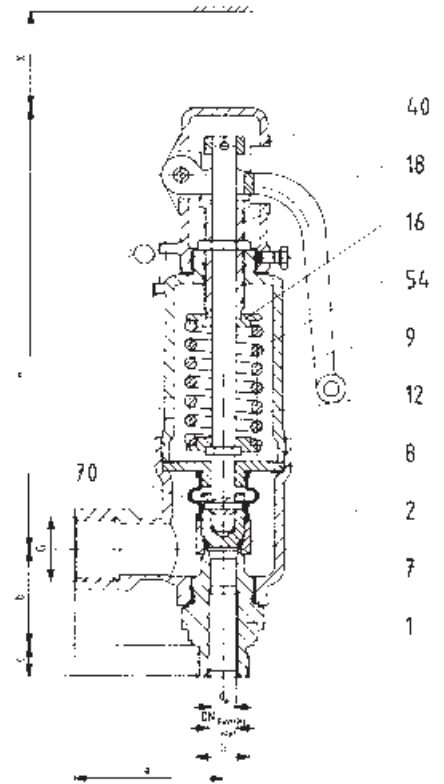

**Type 460**  
mit Anlüftung und Kontrollbohrung  
with lifting device and inspection hole

## Zulassungen/Approvals

	<b>Dämpfe/Gase/Heizung D/G/H</b> <b>Steam/Gases/Heating S/G/H</b>
<b>TÜV (TRD 721)</b> Listennr./Approval number Ausflußziffer/Coefficient of discharge αd Öffnungscharakteristik/Opening characteristic	909 DN 15: 0,81 / DN 20: 0,79 Normal/Standard

<b>Eintrittskörperwerkstoff</b> <i>Body material</i>		<b>Temperatureinsatzgrenze °C</b> <i>Temperature range °F</i>	<b>Artikelnummer</b> <i>Article Number</i>			
DIN EN		bis to	<b>4603</b>	<b>DN/d<sub>o</sub></b>		
Werkstoffbezeichnung <i>Material Designation</i>	Werkstoff-Nr. <i>Material No.</i>			15/13	20/17,5	
X14 CrMoS 17	1.4104	+120/+248			.7853	.7863

Bei Bestellung bitte Artikelnummer entsprechend Bestellbeispiel im Teil 1 und Ansprechdruck angeben.

Please state article number corresponding to the example for ordering in section 1 and set pressure.

Änderungen behalten wir uns vor.

Modifications reserved.

## Abmessungen, Druckbereiche, Gewichte / Dimensions, Pressure Ranges, Weights

Nennweite, Ventilgröße	Nominal Diameter, Valve size	DN	-	15	20								
Eintritt Zapfen	Inlet male	G	-	3/4	1								
Austritt Muffe	Outlet female	G	-	1	1 1/2								
Max. Ansprechdruck	Max. Set pressure	p	bar/bar g	10	10								
Engster Strömungsquerschnitt	Flow area	A <sub>0</sub>	mm <sup>2</sup>	133	241								
Engster Strömungsdurchmesser	Flow diameter	d <sub>0</sub>	mm	13	17,5								
Schenkellänge	Centre to face dim.	a	mm	75	75								
		b	mm	50	54								
Zapfenlänge	Length	c	mm	16	18								
Bauhöhe	Height	H	mm	228	225								
Deckenfreiheit	Height clearance	x	mm	150	150								
Gewicht	Weight	-	kg	2,6	3								

## Werkstoffe / Materials

Pos. Item	Bauteile	Parts	4603 Chromstahl Chrome steel
1	Eintrittskörper	Body (Base)	X 14 Cr Mo S 17 1.4104
2	Austrittsgehäuse	Outlet chamber	GGG-40.3 0.7043
7	O-Ring-Teller	O-ring-disc	X 39 Cr Mo 17-1 / EPDM 1.4122/EPDM
8	Führungsscheibe	Guide	X 14 Cr Mo S 17 tenifer 1.4104 tenifer
9	Federhaube	Bonnet	GGG-40.3 0.7043
12	Spindel	Spindle	X 20 Cr 13 1.4021
16	Federteller	Spring plate	11 S Mn Pb 30 1.0718
18	Druckschraube mit Buchse	Adjusting screw with bush	X 14 Cr Mo S 17 1.4104 PTFE PTFE
54	Feder	Spring	Federstahldraht C/Spring steel wire C X 10 Cr Ni 18-8 1.1200/1.4310
40	Anlüftung H 3	Lifting device H 3	GGG-40 0.7040
70	Faltenbalg	Bellows	EPDM EPDM

Leistungstabelle			Discharge Capacities		
Berechnung entsprechend TRD 721			Calculation of mass flow according to TRD 721		
p	Ansprechüberdruck		Set pressure		bar/bar g
I	Sattdampf		Sat. steam		kg/h
II	Wärmeleistung		Heat capacity		kW

DN	15		20							
d <sub>0</sub> (mm)	13		17,5							
p	I	II	I	II						
1.0	114	72.0	192	117						
1.5	153	92.7	254	154						
2.0	181	110	316	190						
2.5	215	128	377	223						
3.0	245	145	433	256						
3.5	276	162	487	286						
4.0	306	178	540	315						
4.5	336	195	594	344						
5.0	366	211	647	373						
5.5	396	227	700	402						
6.0	426	243	753	430						
7.0	486	275	860	486						
8.0	546	306	965	541						
9.0	606	337	1070	595						
10.0	666	367	1170	649						

S&R Catalog

Edition 05.2015.

**LESER**

[The-Safety-Valve.com](http://The-Safety-Valve.com)

LESER GmbH & Co. KG

20537 Hamburg, Wendenstr. 133-135  
20506 Hamburg, P.O.Box 26 16 51

Fon +49 (40) 251 65-100  
Fax +49 (40) 251 65-500

E-Mail: [sales@leser.com](mailto:sales@leser.com)  
[www.leser.com](http://www.leser.com)